



**Clarity is an ergonomically designed compact seating innovation which offers unsurpassed comfort.**

**This is the perfect choice for discerning venues in need of a stylish look. It has proven to be a popular choice for performing arts auditoriums, educational lecture theatres, arenas and places of worship.**

**All Camatic Seating products are designed in consultation with leading ergonomists and provide hours of seating comfort. The Clarity range can be tailored to blend harmoniously with the most sophisticated of venues.**

**The low maintenance design and comprehensive range of finishes has made Clarity a clear choice for venue operators everywhere.**

**Clarity offers a range of finishes including full upholstery in plush fabrics which bring a richness and warmth to any venue. Seat outer backs in natural timber or easy care polypropylene and a range of arm finishes and accessories are also available.**

**The unique Clarity mounting system enables installations at varying seat centres with alternate back inclinations at the tightest radius rows. The seat also adds to a venue's acoustic ability in all of its standard configurations, and can be further tailored to meet specific acoustic requirements.**

**Moulded polyurethane foam**

The specifically formulated polyurethane foam used to individually mould seats and backrest cushions provides the perfect balance between support and comfort. Our manufacturing process ensures the foam will not collapse or flatten out at any stage and will provide lasting comfort and ergonomic support.

**Variable seat centre system**

The unique variable seat centre system enables optimized installation in either floor mount or riser mount configuration. Combined with this option is the ability to space seats at various intervals, providing a range of seat centres and creating a best fit installation.

**Gravity tilt seats**

Innovative gravity tilt seats using fully enclosed counterweights are silent and reliable – a sensible alternative to high maintenance and unreliable pivot springs.

**Armrests**

Clarity has many standard armrest options including a club style, writing tablets and a no arm alternative. All armrests, held securely by a single locking screw, can be interchanged or upgraded to any of the available alternatives at a later stage.

**Laminated fabrics**

All Clarity covers are easily replaceable and feature foam backed fabric for stretch control and elimination of seam slippage and sagging.

**Ease of assembly**

Once standards have been installed, the seats and backrests effortlessly glide into place and are securely locked into position. Similarly, damaged seats can be replaced at any stage without affecting neighboring seats.

**Use of recycled plastics**

In an effort to minimize the effect on the environment, recycled plastics are used in the moulding of non structural components, such as seat and back upholstery inners. All plastic components bear the recycling code identification marking, compliant with worldwide recycling standards.

**Clarity Features**

	Tilt	Concerto	Pedestal	Club	Scholar
Tread or riser mounting system	•	•		•	•
Innovative standards cover multiple seat centres	•	•	•	•	•
Krantz air diffuser system (tread mounting only)			•		
Ergonomic profile offers enduring comfort	•	•	•	•	•
Individually moulded polyurethane seat and backrest cushions	•	•	•	•	•
Gravity tilt seat – silent and reliable, with zero maintenance	•	•	•	•	•
Zip removable seat and backrest covers	•	•	•	•	•
Multiple armrest options	•	•			
Various back and seat outer finishes	•	•	•	•	•
Easy installation with minimal fixings	•	•		•	•

**Options**

Seat numbers	•	•	•	•	•
Row panels and identification (including backlit row ID)	•	•	•	•	•
Fixed arm options – plastic/upholstered/timber	•	•	•	•	•
Lift-up armrests – plastic/upholstered/timber (ADA compliant)	•	•	•	•	•
Club style armrests – row ends or throughout venue	•	•		•	•
Upholstered/timber or plastic back outer	•	•	•	•	•
Upholstered/timber seat outer	•	•	•	•	•
Removable system – single and two seat units	•	•	•	•	•
Beam mounting available					•
Fold-out writing tablet	•	•	•	•	•



### Clarity Tilt

Clarity Tilt is a versatile and supremely comfortable modern seat that provides venue owners with a range of options when space is at a premium. This compact seat's ergonomic design is also conducive to sitting for long periods.

While patrons enjoy the lumbar support and well positioned armrests of Clarity Tilt, venue operators appreciate that it can be tailored for the most sophisticated of venues.

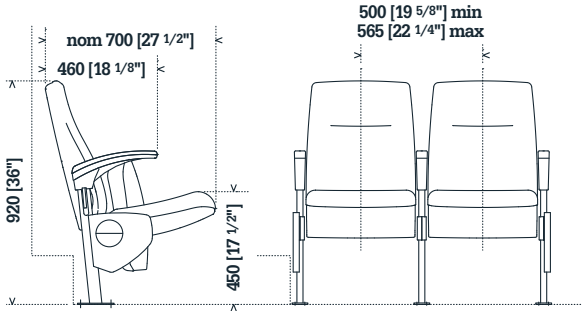

### Clarity Concerto

Clarity Concerto is a classic choice for any performing arts venue. Timber veneer outers can be made to match to other timbers used in the building. These timbers not only add warmth to a venue, their reflective properties can assist in achieving the best acoustic level for performing arts. Clarity's silent gravity tilt seat ensures unwanted sounds are never heard during or after a performance.

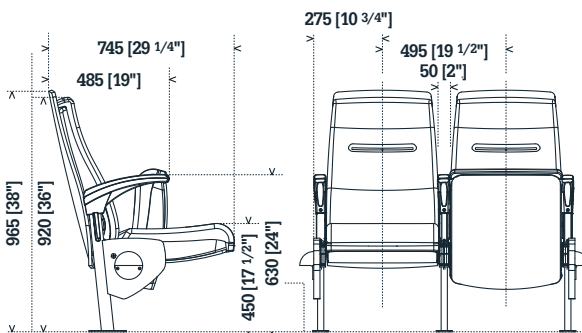

### Clarity Pedestal

Clarity Pedestal is an individual seat that can suit the most complex venue designs. It can be installed to any radius, no matter how tight, to ensure the number of seats are maximized and without any compromise of comfort or seat performance. The silent gravity tilt seat promises no unwanted sounds during or after a performance.

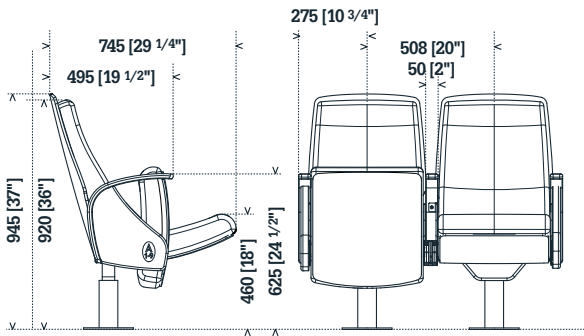

### Clarity Club

Clarity Club is unequalled in providing long-term seating comfort, modern design and superior quality. It features Camatic Seating's signature ergonomic design, fully enclosed box-style armrests and a silent gravity tilt seat. A range of back options and finishes are available to suit the look of any venue.

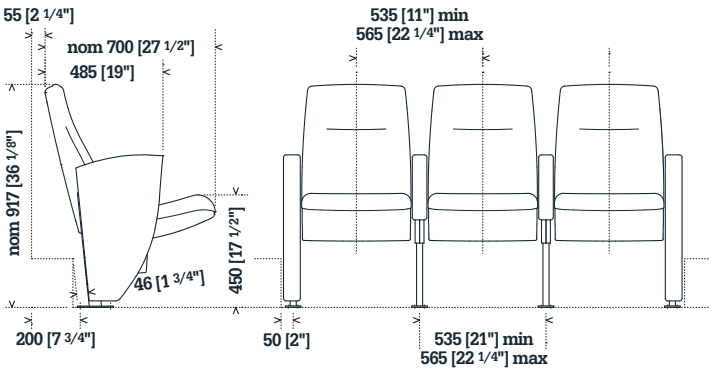

### Clarity Scholar

When a writing surface is required without a significant loss of seating numbers, Clarity Scholar is at the head of the class. The addition of the tablet only marginally increases the overall dimensions of the seat so it can be used on the tightest of row spacing and seat centres. The tablet mechanisms are robust and safe with laminated writing surfaces that are virtually indestructible.

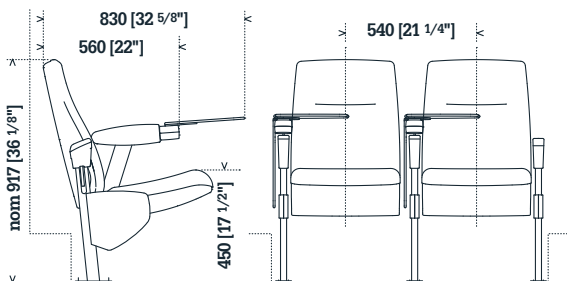

**Australia**

Head Office & Manufacturing  
Camatic Pty Ltd  
93 Lewis Road  
Wantirna South  
Victoria 3152 Australia  
Telephone: 61 3 9837 7777  
Facsimile: 61 3 9837 7700  
Email: sales@camatic.com  
www.camatic.com

**USA**

Camatic Seating Inc  
1010 West Eules Blvd  
Suite 110, Eules  
TX 76040 USA  
Telephone: 1 682 503 5317  
Facsimile: 1 817 633 2190

# CAMATIC

**Representation**

Australasia  
South East Asia  
North America  
Europe  
Middle East  
CIS